

#### Oceľové bočnice typu B:

Osvedčený typ profilu pre vysoké zaťaženie, je používaný prevažne ako bočnicový profil pre poľnohospodárske sklápače, rovnako ako rozmetače hnojív.

#### Steel sideboards type B:

These well tried Sideboards are designed for heavy side pressure applications, especially useful for mounting as side walls in agricultural tippers, tipper-top structures and manure spreaders.

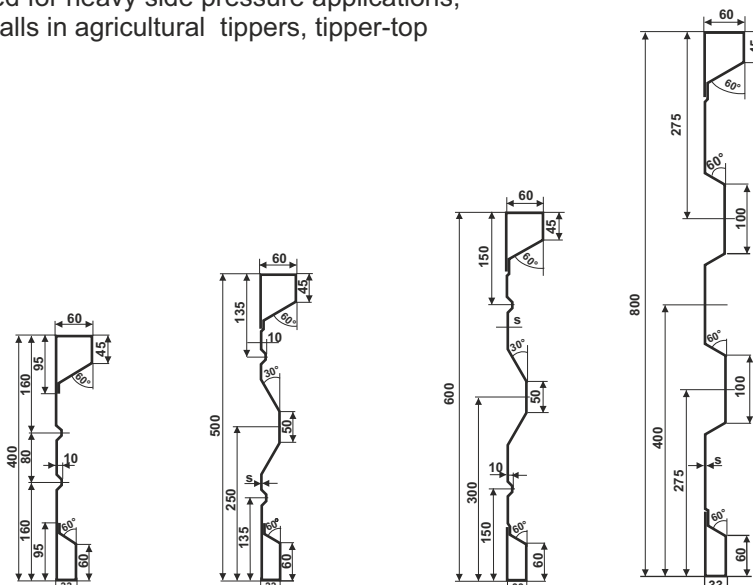

Typ	B 400	B 500		B 600		BTT 800
s /mm/	2,0	2,0	2,5	2,0	2,5	2,5
kg/m	11,6	13,4	16,8	15,0	18,8	23,6

#### Oceľové bočnice typu BN/BNS:

Osvedčený typ profilu pre vysoké zaťaženie s profilovanou tesniacou lištou, je používaný ako bočnica poľnohospodárskych sklápačov a nákladných valníkov s veľkou tesnosťou.

#### Steel sideboards type BN/BNS:

These well tried steel sideboards are designed for heavy side pressure applications with an adjusting or covering edge on the outside. They are especially suitable for mounting as side walls in agricultural tippers, tipper-top structures with a high tightness requirement

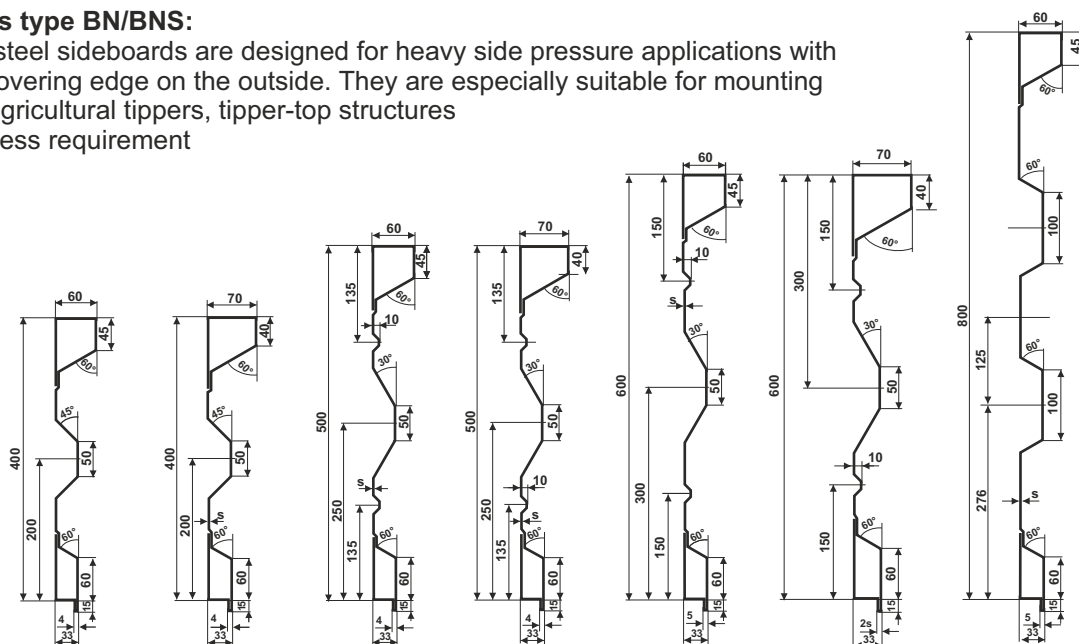

Typ	BNkT 400	BNSkT 400	BN 500	BNS 500	BN 600	BNS 600		BNTT 800
s /mm/	2,0	2,0	2,0	2,0	2,5	2,0	2,5	2,5
kg/m	12,3	12,5	13,9	14,0	19,3	15,7	19,5	24,1

### Oceľové bočnice typu BAK/BAKS:

Profil pre nadstavby pre vysoké zaťaženie s valcovanou tesniacou lištou na vnútornej strane pre poľnohospodárske a automobilové sklápače

### Steel sideboards type BAK/BAKS:

These are top-structure side walls with an adjusting or covering edge inside, especially useful for mounting as a top side wall on agricultural tippers and tipper-top structures.

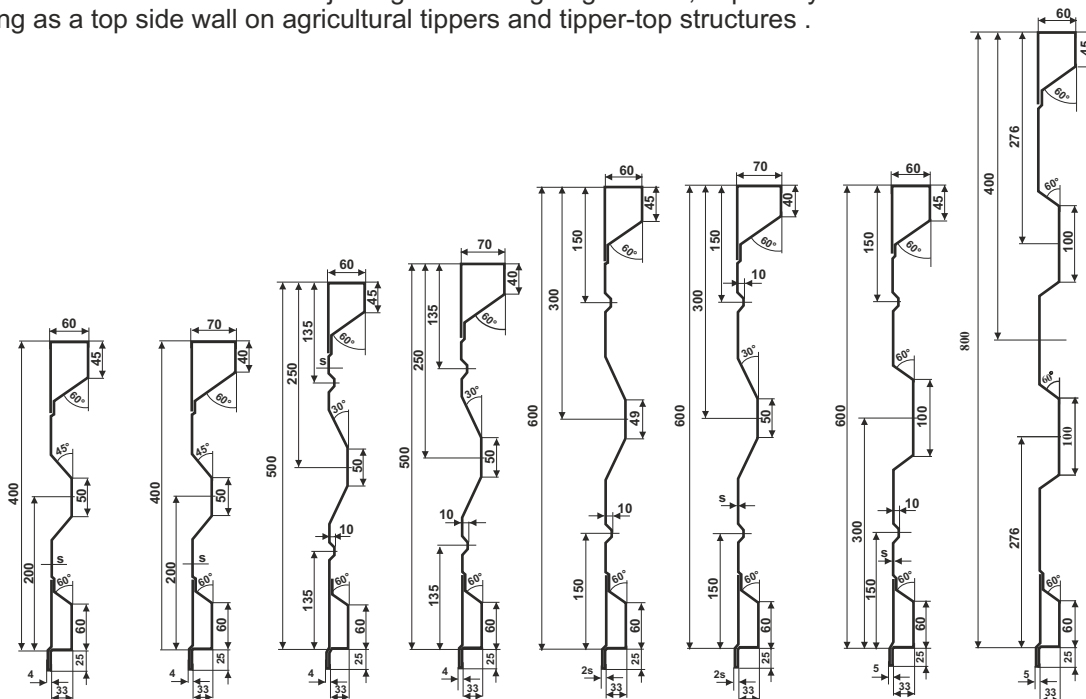

Typ	BAKkT 400	BAKSkT 400	BAK 500	BAKS 500	BAK 600	BAKS 600	BAKT 600	BAKTT 800
s /mm/	2,0	2,0	2,0	2,0	2,0	2,5	2,0	2,5
kg/m	12,7	12,9	14,2	14,4	15,8	19,8	16,0	20,0

### Oceľové bočnice typu HV:

Oceľový profil pre čelné a zadné steny poľnohospodárskych a automobilových sklápačov, ako aj bočnice ľahkých nákladných automobilov a prívesov za osobné autá

### Steel sideboards type HV:

These steel sideboards are designed for use as front and rear profiles on agricultural tippers, tipper-top structures, side walls for personal car trailers and light side wall applications.

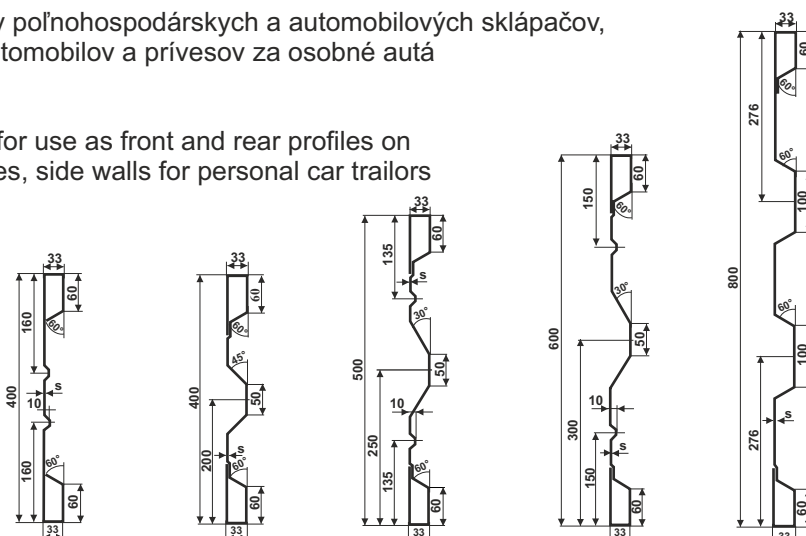

Typ	HV 400			HVkT 400	HV 500		HV 600		HVTT 800
s /mm/	1,25	1,5	2,0	2,0	1,5	2,0	1,5	2,0	2,0
kg/m	6,8	8,2	10,9	11,2	9,6	12,8	10,8	14,3	18,3

**Oceľové bočnice typu HVN:**

Profil pre čelné a zadné steny na plošiny s profilovanou tesniacou lištou pre poľnohospodárske a automobilové sklápače.

**Steel sideboards type HVN:**

Steel sideboards with an adjusting or covering edge outside for the use as a front, rear profile on agricultural tippers and tipper-top structures.

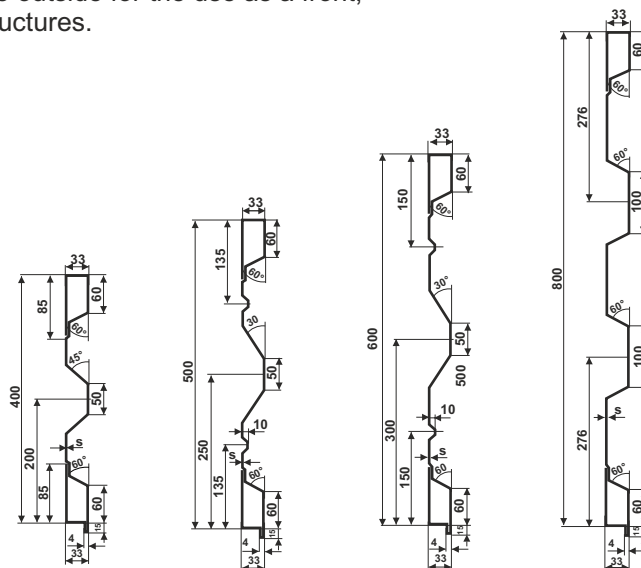

Typ	HVNkT 400	HVN 500	HVN 600	HVNTT 800
s /mm/	2,0	2,0	2,0	2,0
kg/m	11,7	13,2	14,8	18,7

**Oceľové bočnice typu HVAK:**

Profil pre čelné a zadné steny s vnútornou tesniacou lištou pre poľnohospodárske a automobilové sklápače.

**Steel sideboards type HVAK:**

These top-structure front, rear walls with an adjusting or covering edge inside, are especially for mounting on a agricultural tippers and tipper-top structures.

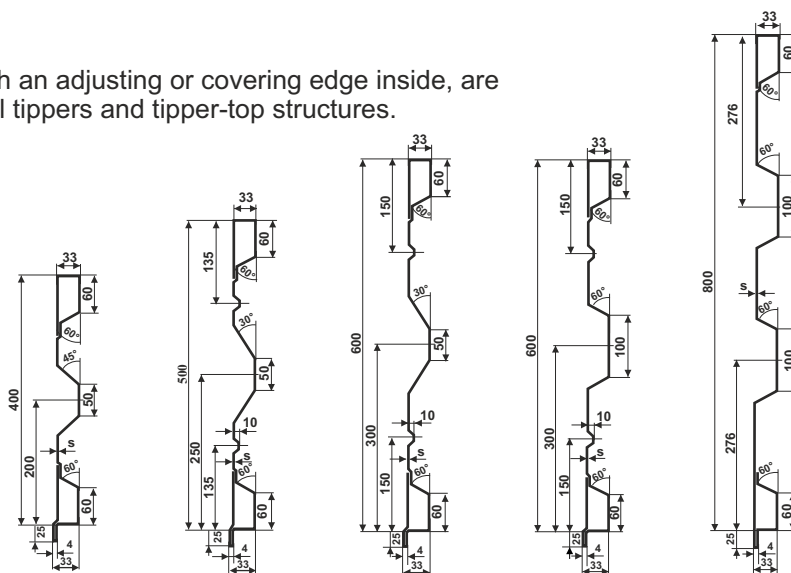

Typ	HVAKkT 400	HVAK 500	HVAK 600	HVAKT 600	HVAKTT 800
s /mm/	2,0	2,0	2,0	2,0	2,0
kg/m	12,0	13,6	15,2	15,5	19,0

### Doplnkové profily

### Additive profiles

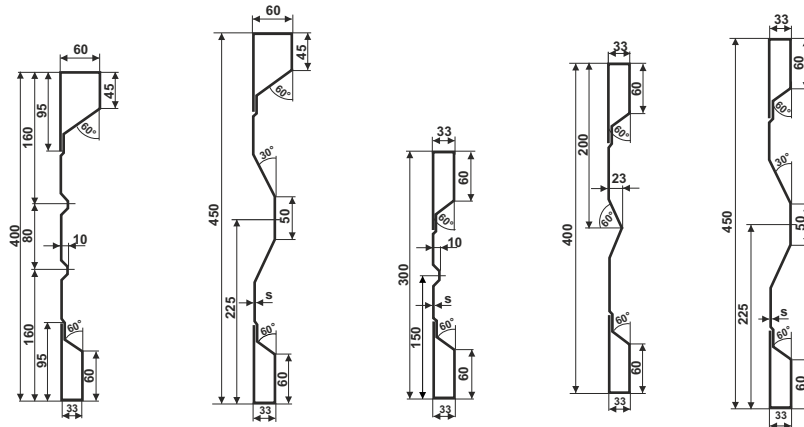

Typ	B 400	B 450	HV 300	HVD 400	HV 450
s /mm/	1,5	2,0	2,0	2,0	2,0
kg/m	8,7	12,6	9,3	11,0	11,9

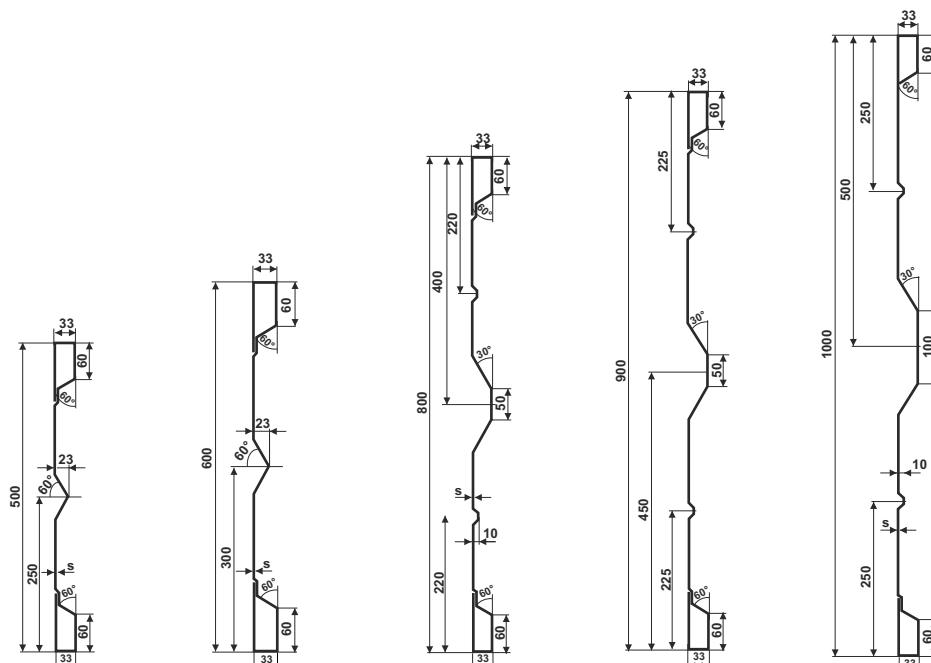

Typ	HVD 500	HVD 600	HV 800	HV 900	HVW 1000
s /mm/	2,0	2,0	2,0	2,0	2,0
kg/m	12,7	14,3	17,5	19,1	20,7

#### Doplnkové profily BN/BNS

Additive profiles BN/BNS

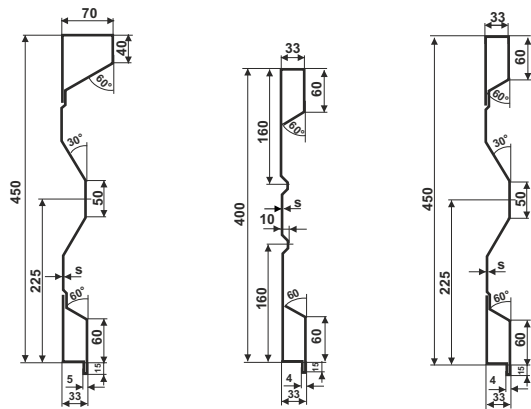

Typ	BNS 450	HVN 400	HVN 450
s /mm/	2,5	2,0	2,0
kg/m	16,7	11,4	12,4

#### Doplnkové profily BAK/HVAK

Additive profiles BAK/HVAK

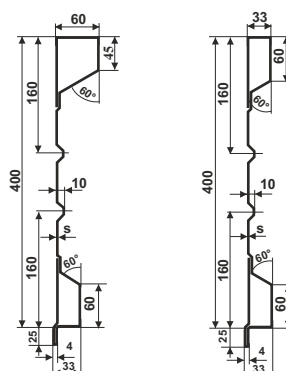

Typ	BAK 400	HVAK 400
s /mm/	2,0	2,0
kg/m	12,4	11,7

#### Špeciálne profily

Special profiles

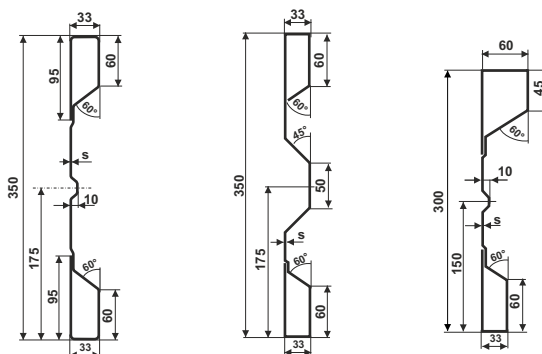

Typ	HV 350	HVkT 350	B 300
s /mm/	2,0	2,0	2,0
kg/m	10,1	10,4	10,0

**Oceľové bočnice typu "FOX":**

Bočnicové profily typu "FOX" sa vyrábajú z materiálu HARDOX 400 s hrúbkou 4 mm. Tieto bočnicové panely sú vyrábané pre vysoké zaťaženie na kamiónoch a návesy.

**Steel sideboards type "FOX":**

As a further new product is our sidepanel type "FOX" produced in material HARDOX 400 and thickness 4 mm. This sideboard is done for extremely heavy use in truck and trailers.

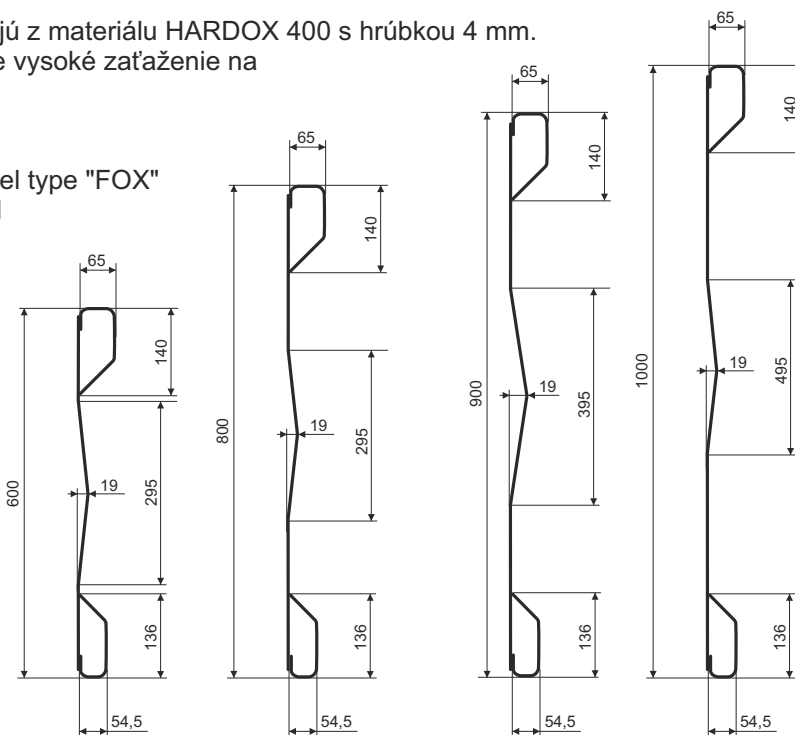

Typ	FOX 600	FOX 800	FOX 900	FOX 1000
s /mm/	4,0	4,0	4,0	4,0
kg/m	32,4	38,6	41,8	44,9

**Oceľové bočnice typu "FHD":**

Technická inovácia bočnicových profilov s hrúbkou 3 mm z materiálu S500. Tieto panely sú vyrábané nepretržitým zvaraním - špeciálne kvôli vysokému zaťaženiu na kamiónoch a návesoch.

**Steel sideboards type "FHD":**

As a further technical innovation, we are offering now sidepanels as well in thickness 3 mm and material S500. These profiles are also produced with continuous welding - specially for heavy using for trucks and trailers.

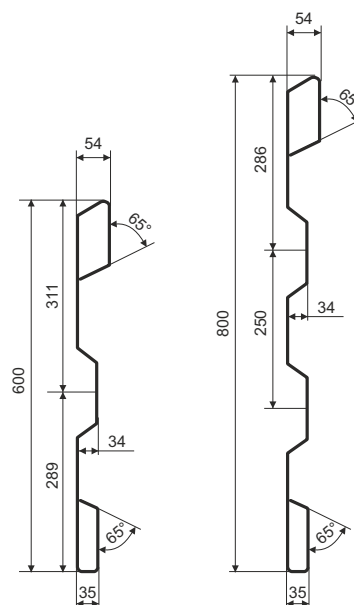

Typ	FHD 600	FHD 800
s /mm/	3,0	3,0
kg/m	22,9	28,4

Oceľové bočnicové profily Steel sideboards				
Kód Code	Výška (mm) Height (mm)	Hrúbka steny (mm) Wall thickness (mm)	Dĺžka (m) Length (m)	Hmotnosť Weight
115355	350	1,5	5	7,300 kg/m
115405	400	1,5	5	7,900 kg/m
115505	500	1,5	5	9,200 kg/m
115605	600	1,5	5	10,400 kg/m
120505	500	2	5	12,100 kg/m
120605	600	2	5	13,700 kg/m
125805	800	2,5	5	23,300 kg/m
115356	350	1,5	6	7,300 kg/m
115406	400	1,5	6	7,900 kg/m
115506	500	1,5	6	9,200 kg/m
115606	600	1,5	6	10,400 kg/m
120506	500	2	6	12,100 kg/m
120606	600	2	6	13,700 kg/m
125806	800	2,5	6	23,300 kg/m

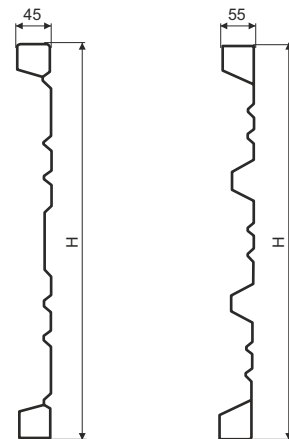

Bočnice hrúbka  
1,5 - 2 mm

Bočnice hrúbka  
2,5 mm

Lemovanie Edging			
Kód/Code	Výška (mm) Height (mm)	Hrúbka steny (mm) Wall thickness (mm)	Hmotnosť (kg) Weight (kg)
115350	350	1,5	0,600
115400	400	1,5	0,680
115500	500	1,5	0,850
115600	600	1,5	1,020
120500	500	2	1,120
120600	600	2	1,330
125800	800	2,5	2,380

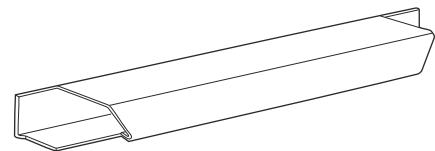

Profilované lemovanie Profiled edging			
Kód/Code	Výška (mm) Height (mm)	Hrúbka steny (mm) Wall thickness (mm)	Hmotnosť (kg) Weight (kg)
112810	400	2	0,840
112811	500	2,5	1,530
112812	600	2,5	1,880
112813	800	2,5	2,540

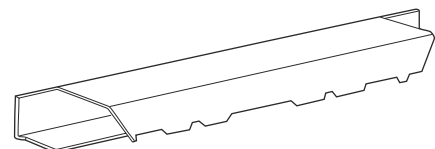

Výstuha Stiffener			
Kód/Code	Výška (mm) Height (mm)	Hrúbka steny (mm) Wall thickness (mm)	Hmotnosť (kg) Weight (kg)
115351	350	1,5	0,403
115401	400	1,5	0,460
115501	500	1,5	0,580
115601	600	1,5	0,690
120501	500	2	0,820
120601	600	2	1,000
125801	800	2,5	1,840

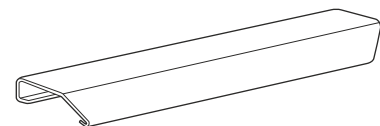

Profilovaná výstuha Profiled stiffener			
Kód/Code	Výška (mm) Height (mm)	Hrúbka steny (mm) Wall thickness (mm)	Hmotnosť (kg) Weight (kg)
112710	400	2	0,560
112711	500	2,5	1,050
112712	600	2,5	1,350
112713	800	2,5	1,840

